

P - GATE: ELEVATION / SECTION

ARM LENGTH SCHEDULE:

TRAIL WIDTH	ARM LENGTH
2400 MM	1800 MM
3000 MM	2100 MM

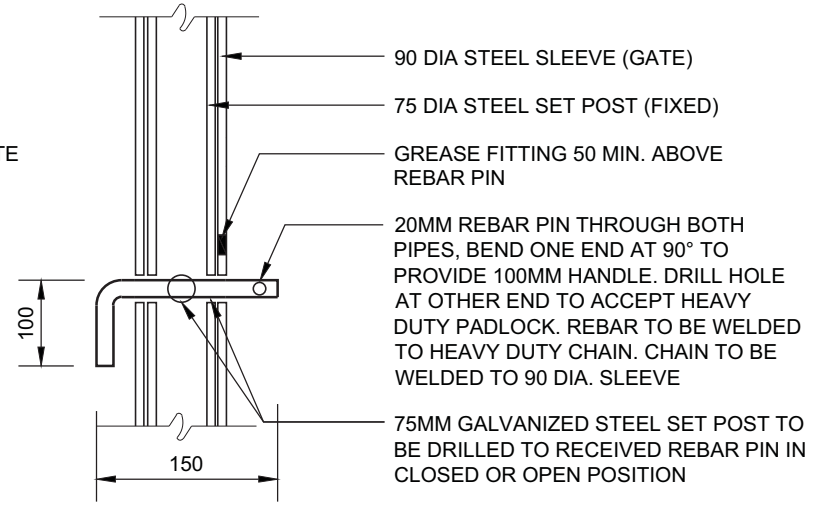

LOCKING DEVICE: SECTION

NOTES:

1. ALL PIPE AND COMPONENTS TO BE GALVANIZED AFTER FABRICATION (TYP.).
2. ALL PIPE SHALL BE SCHEDULE 40 STEEL.
3. ALL WELDS TO BE 5 MM CONTINUOUS SEAM AND GROUND SMOOTH.
4. CONTRACTOR TO SUPPLY HEAVY DUTY PADLOCK AS REQUIRED.
5. CONTRACTOR TO SUBMIT SHOP DRAWINGS.
6. ALL MEASUREMENTS ARE IN MILLIMETRES UNLESS STATED OTHERWISE.

P - GATE OPTION 2

JUNE 2015

SITE AMENITIES - SERIES 800

L842

N.T.S